



Lab. Rules and Introduction to Electronic Instruments

實驗室規則及儀器介紹

Chia-Chun Tsai

Lab. Rules



- **No games** 嚴禁嬉戲
Safety is first 安全第一
- **No foods, No drinks** 嚴禁飲食
Worry mouse and cockroach to damage instruments
- **Use instruments carefully and return them
homing really after finishing** 愛惜器材,用完確實整理歸位
- **Instruments checklist of each group**
各組確實填寫儀器檢查表
- **Instruments checklist in summary**
課程班代確實填寫儀器檢查總表

Chia-Chun Tsai

2

C-C
Tsai

Objectives 教學目標



- Understand all related electronic hand tools 電子手工具
- Understand how to operate basic electronic instruments 電子儀器, such as **DMM** 數位電表, **Power Supply** 電源供應器, **Function Generator** 函數波產生器, and **Oscilloscope** 示波器.

Chia-Chun Tsai

3

Hand Tools 手工具



Single core cable or Wires



Needle-nose pliers



Diagonal pliers



Screwdriver set



IC chip extractor



Soldering iron



Alligator Clips



Test Clips



60/40 Lead Solder, rosin core .062" 1lb



Chia-Chun Tsai

4



VOM or DMM 電表

- A VOM or DMM can measure resistance, DC voltage/current, AC voltage, and other Components.

Analog multimeter (VOM)



(b) Analog multimeter (VOM)

Digital multimeter (DMM)

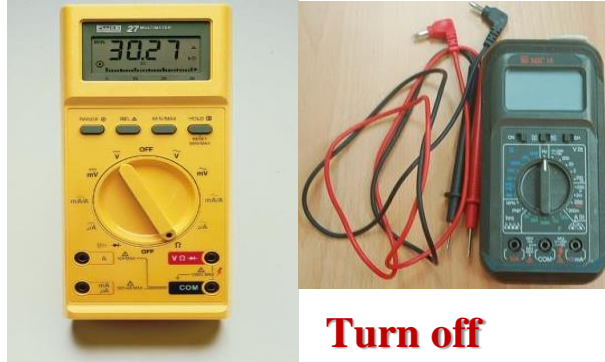

(a) Hand-held digital multimeter (DMM)
(Reproduced with permission from the Fluke Corporation)

Turn off
when no use

Chia-Chun Tsai



Measure Resistance 量測電阻

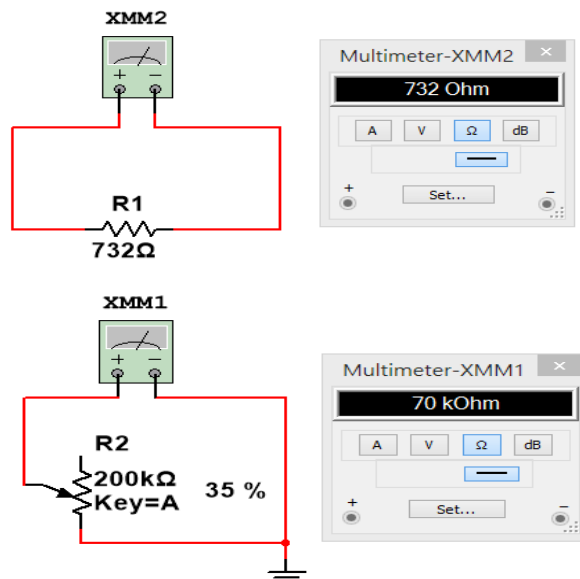

Chia-Chun Tsai

Measure Resistance

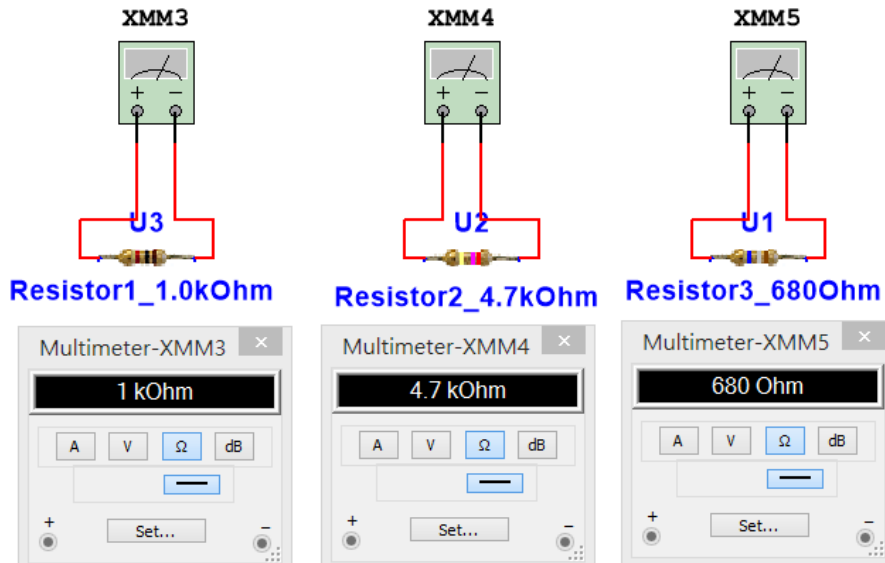

Chia-Chun Tsai

7

Measure DC & AC Voltages

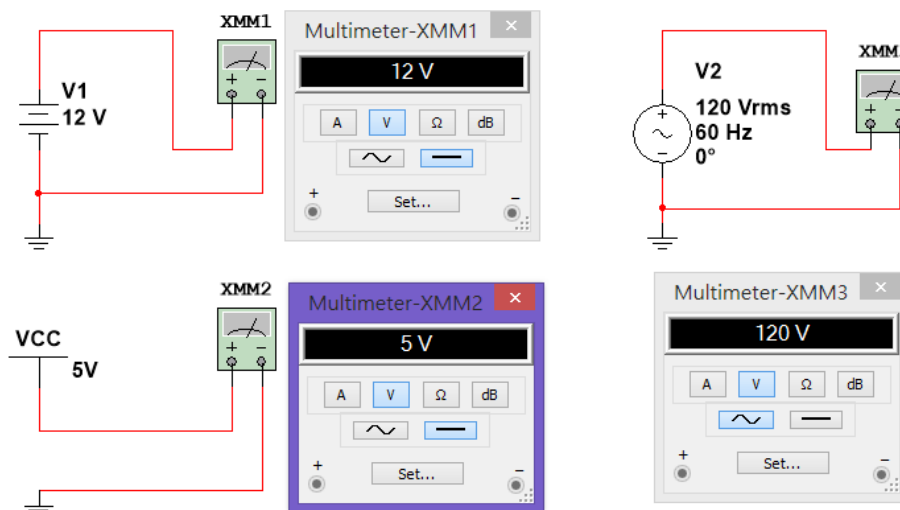

Chia-Chun Tsai

8

Measure 3-Phase AC Voltages

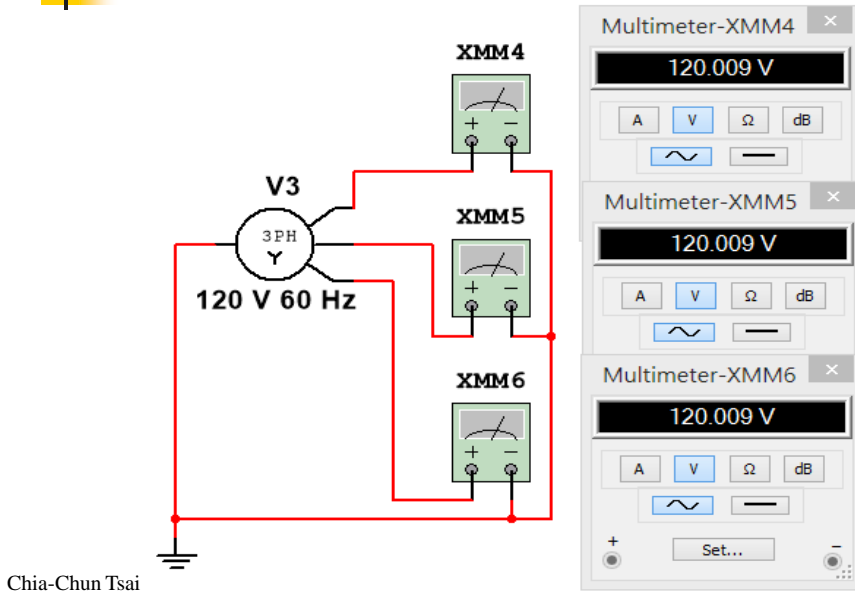

9

Measure DC & AC Currents

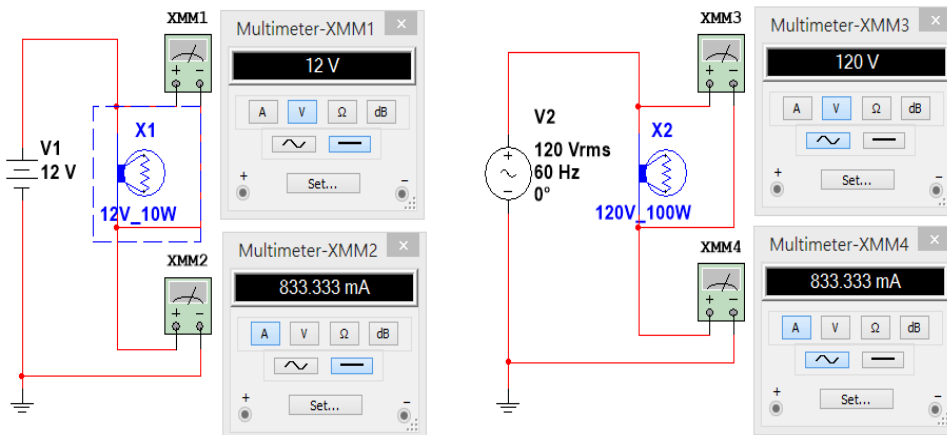

Chia-Chun Tsai

10

Power Supply-1 電源供應器



- A power supply can support at least two DC voltages / currents.



0~ +30V, 3A
0~ -30V, 3A
Fixed 5/3.3V

Source: Motech LPS-305 2-group voltages

Chia-Chun Tsai

11

Basic Operations for Motech LPS-305



- Push button “7” +**VSET** to set **positive V+** to COM
- Push button “8” +**ISET** to set **limited current** of V+
- Push button “1” to select the **toggle INDEP/TRACK**
- Push button “2” to select the **toggle 5V/3.3V**

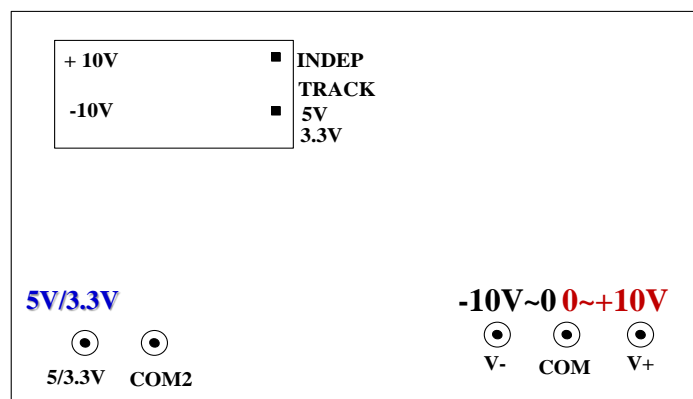

Chia-Chun Tsai

12

Basic Operations for Motech LPS-305



- Push button “2” to select the toggle 5V/3.3V
- Push button “.” to on/off output 5V/3.3V



Chia-Chun Tsai

13

Basic Operations for Motech LPS-305



- Push button “7” + **VSET** to set positive $V+$ to COM
- Push button “5” to set $V+ = 5V$
- Push button “on/off” to output 5V



Chia-Chun Tsai



Power Supply-2

- A power supply can support at least two DC voltages / currents.

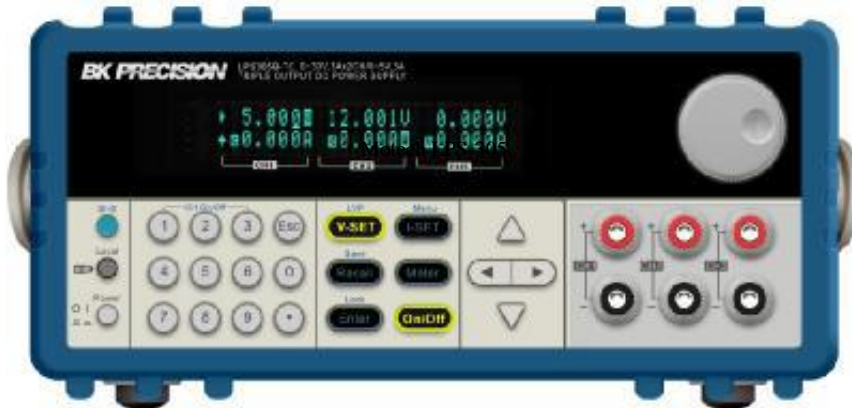

Source: BK Precision LPS305B-TC 3-group voltages

Chia-Chun Tsai

15

Basic Operations for BK LPS305B-TC



- Push button **V-set** (LED on for setting) + Number + **Enter** to set the **output voltage**
- Push button **I-set** (LED on for setting) + Number + **Enter** to set the **output current**
- Push button **Local** to select other **CHannel** for setting
- Push button **shift**+“**1**”, +“**2**”, or +“**3**” to output the respective **CHannel**
- **Meter**: LED on for measuring; LED off for setting
- **On/Off**: LED on/off for VFD panel on/off
- **Recall**: LED on to recall the stored setting powers
- **CV**: Constant voltage mode
- **CC**: Constant current mode
- **LVP**: Limited Voltage Peak

Chia-Chun Tsai

16

Function Generator 函數波產生器



- A **Function Generator** can output at least **four kinds of waveforms: Sinusoidal, Square, Ramp/Triangle, and Arbitrary waves.**



Chia-Chun Tsai

Source: SIGLENT SDG100

17

SIGLENT SDG100

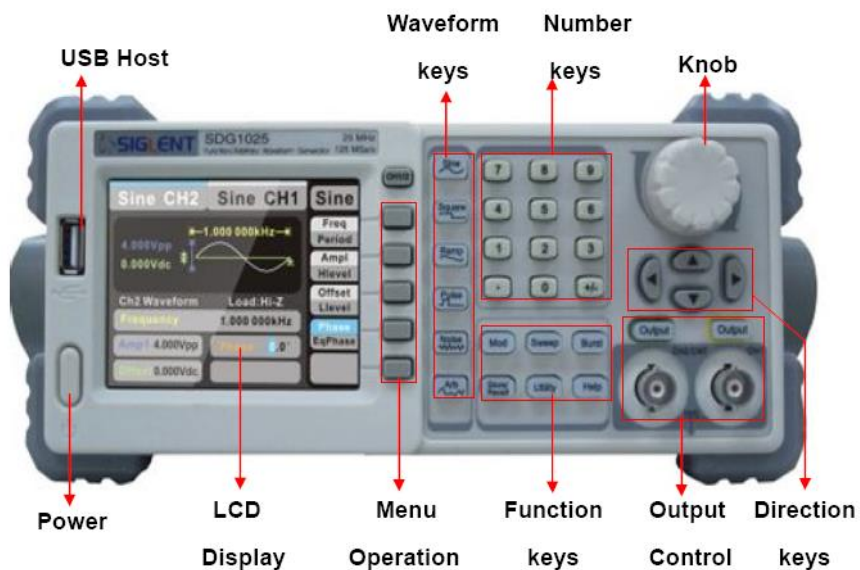

Chia-Chun Tsai

Source: SIGLENT SDG100

18



SIGLENT SDG100

- Sine or Square waveform: 1 μ Hz to 50MHz
- Ramp/Triangle waveform: 1 μ Hz to 300kHz
- Pulse: 500 μ Hz to 5MHz
- Arbitrary waveform: 1 μ Hz to 5MHz



Chia-Chun Tsai

Source: SIGLENT SDG100



SIGLENT SDG100

Waveform	CH2 Settings	CH1 Settings
Sine	Ampl: 0.000Vpp, 0.0mVdc	Freq: 1.000 000MHz
Square	Duty: 4.000Vpp, 0.0mVdc	Freq: 1.000 000MHz, Duty: 50.0%
Ramp	Frequency: 4.000Vpp, 0.0mVdc	Freq: 1.000 000kHz, Phase: 0.0°, Sym: 50.0%
Pulse	Width: 4.000Vpp, 0.0mVdc	Freq: 1.000 000kHz, Width: 200.0us, Delay: 0.0us

Chia-Chun Tsai

Source: SIGLENT SDG100

A Square Waveform to LED

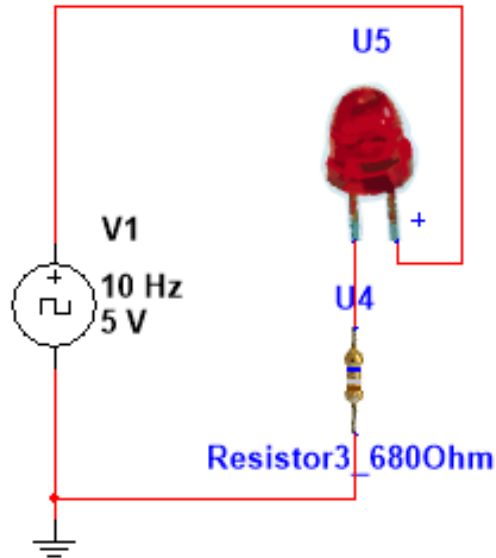

Chia-Chun Tsai

21

Oscilloscope 示波器



- An Oscilloscope (or Scope) can measure any waveforms such as Sinusoidal, Square, Pulse, or Triangle waveforms.

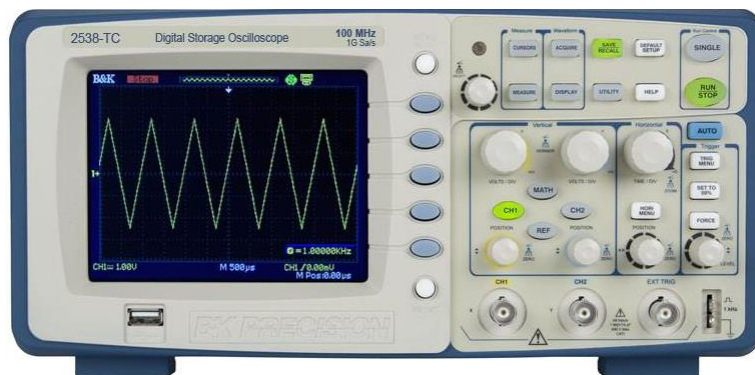

Chia-Chun Tsai

Source: BK Precision 2536-TC (70MHz)

22

Scope- BK 2536-TC

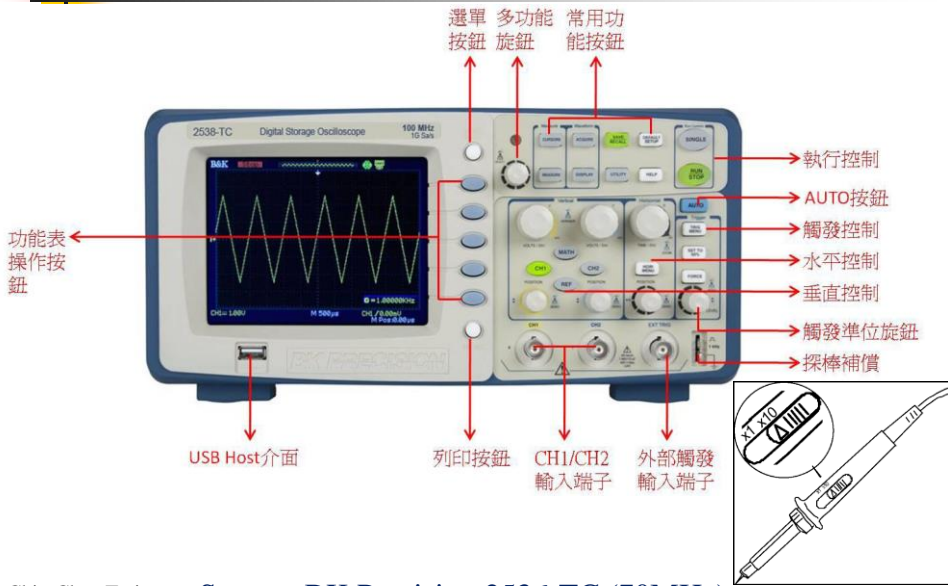

Chia-Chun Tsai

Source: BK Precision 2536-TC (70MHz)

23

Basic Operations- BK 2536-TC

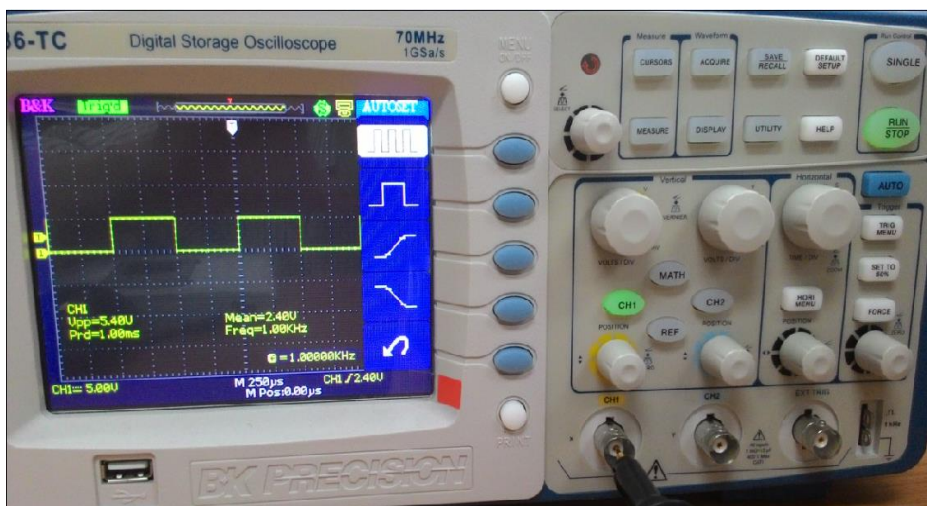

Chia-Chun Tsai

Source: BK Precision 2536-TC (70MHz)

24

Basic Operations- BK 2536-TC

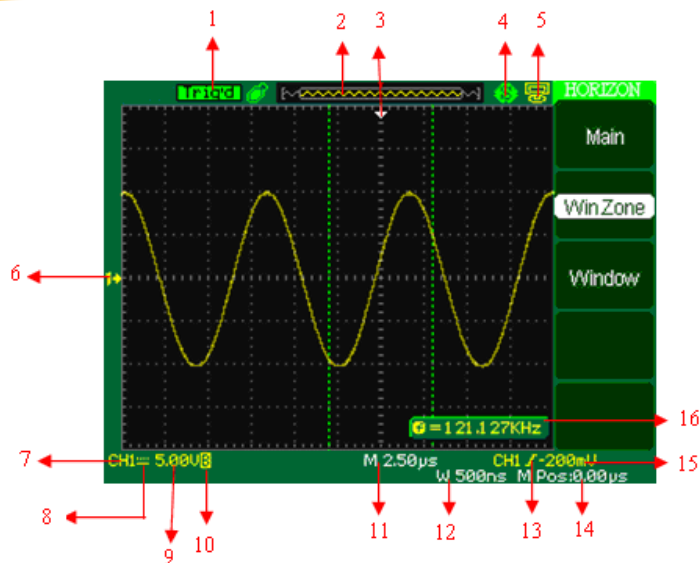

Chia-Chun Tsai

Source: BK Precision 2536-TC (70MHz)

25

Basic Operations- BK 2536-TC



1. Trigger state: **Trig** - d- Triggered; Ready; Scan; Auto; Stop
2. Current wave in the memory
3. Mark the triggering position
4. **P / S** for printing / storing picture
5. to set the rear USB to computer or printer ◦
6. Channel marker
7. CH1
8. CH1 coupling marker ◦
9. CH1 Vertical parameter
10. B: CH1 limited bandwidth
11. Main timebase
12. Horizontal position of main timebase
13. Triggered type
14. Real time
15. Triggered level
16. Frequency

Chia-Chun Tsai

26

Basic Operations- BK 2536-TC



Chia-Chun Tsai

27

Basic Operations- BK 2536-TC



CH1、CH2：

MATH： Display “math functional table” e.g. CH1+CH2

REF： Display “refer-wave functional table”

HORI MENU： Display “horizontal functional table”

TRIG MENU： Display “trigger functional table”

SET TO 50%： Set trigger level at 50%

FORCE： Normal Trigger or just one-shot

SAVE/RECALL： Display “storing/recalling functional table”

ACQUIRE： Display “sampling functional table”

MEASURE： Display “auto measuring functional table”

CURSORS： display “cursor functional table”

DISPLAY： Display “display functional table”

UTILITY： Display “help-tool functional table”

DEFAULT SETUP：

HELP：

AUTO：

RUN/STOP： Continue/Stop to sample a series waves

SINGLE： Sampling a single wave then stop

Chia-Chun Tsai

28

Measure Square/Sine Waves

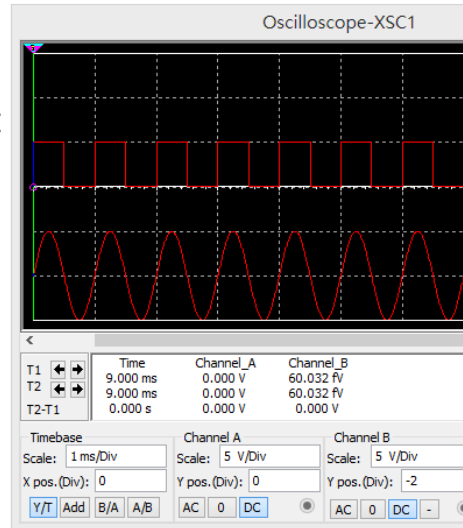
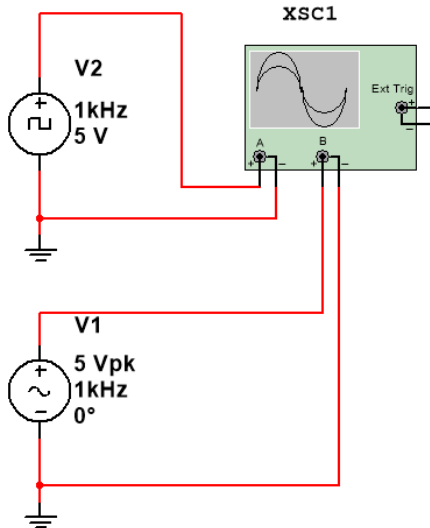

Chia-Chun Tsai

29

FG Output Waveforms for Scope

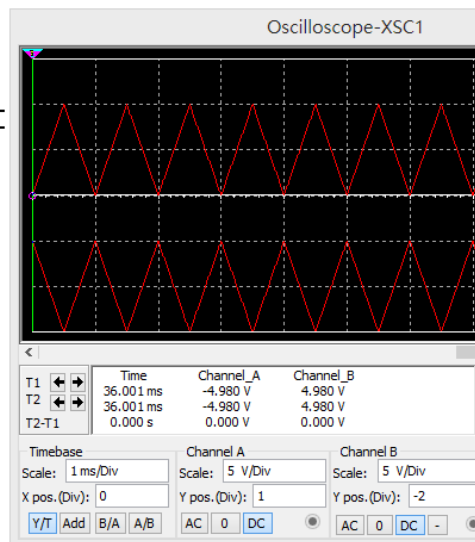
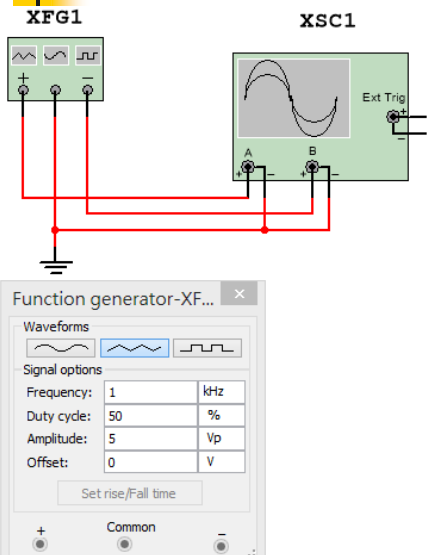

Chia-Chun Tsai

30

Experiments 1~4



1. Can get a voltage source, e.g., 12V, 5V or 3.3V from Power Supply. Please give an example.
2. Can use DMM to measure the resistance, short or open of a wire, DC voltage/current, and AC voltage/current. Please give some examples.
3. Can get a waveform source, e.g., sinusoidal, square, pulse, or ramp/triangle waveform with a voltage (12Vp-p) and a frequency (12kHz) from Function Generator. Please give some examples.
4. Can use oscilloscope to measure a DC voltage and any waveform with their period and frequency. Please give some examples.