



Basic Electricity

基礎電學

Chia-Chun Tsai

Professor (Part-time)

蔡加春 教授

**Dept. of Computer Science and
Information Engineering**

Nanhua University

E-mail: chun@nhu.edu.tw

<http://www.nhu.edu.tw/~chun>

Spring 2022

Description for Basic Electricity

基礎電學 課程概述

本課程針對資訊工程領域所需之基礎電學知識作概括性的介紹，從電的認識至電路的分析，以作為資工領域在建置硬體系統應用的基本專業養成。這些知識主題包含電的特性與單位、認識電的基本元件(電阻、電容及電感等)、元件的串聯與並聯、分壓與分流定則、直流網路分析(歐姆定理、戴維寧定理及諾頓定理等)、直流暫態電路及諧振電路等。 This course presents an introductory survey of basic electricity in information engineering. It follows a bottom-up arrangement of subjects that progresses from the basic electric knowledge to circuit analysis and makes all the hardware system applications for information technologies. These covered topics are as follows: electric characteristics and units, introduction to electric components, series and parallel circuits, DC network analysis, DC transient-state circuits, and resonant circuits.

Textbook 教科書

Circuit Analysis: Theory and Practice

電路分析：理論與實務

5th Edition, 2013

By

Allan H. Robbins

Wilhelm C. Miller

©Delmar Cengage Learning

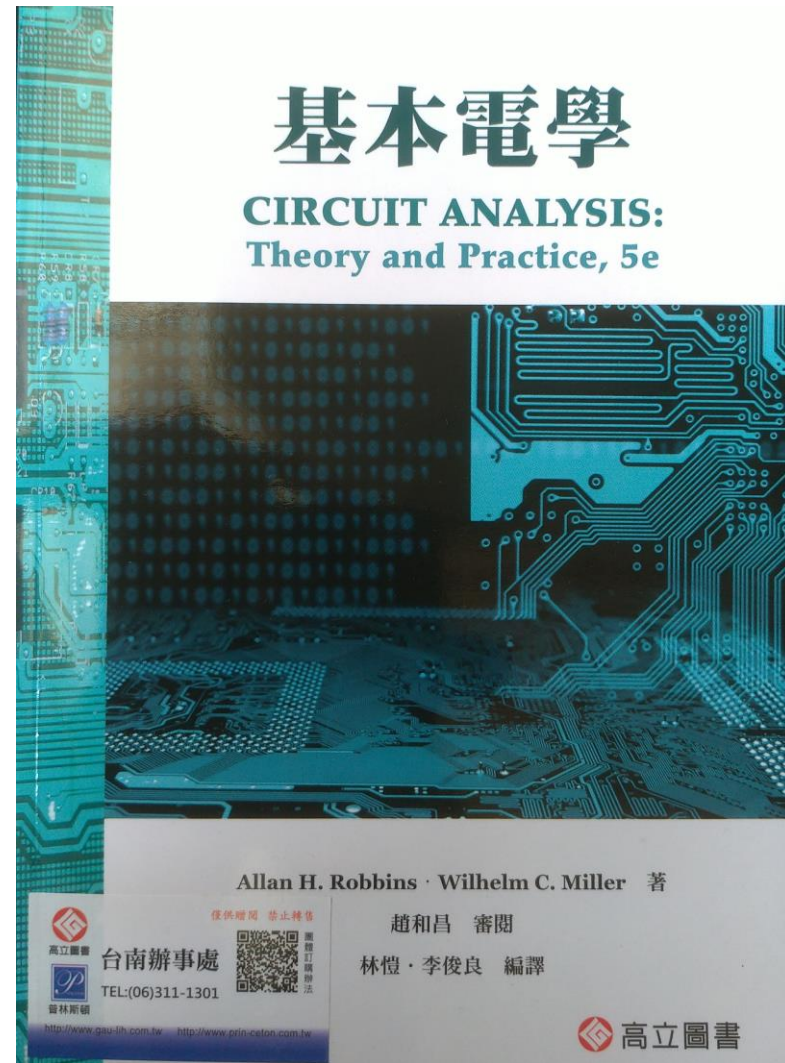

Textbook Cover 教科書 封面

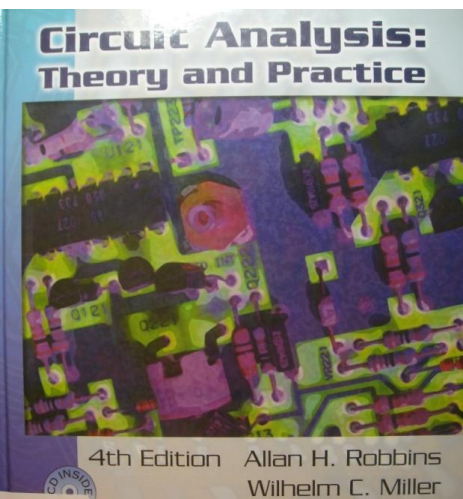

2008

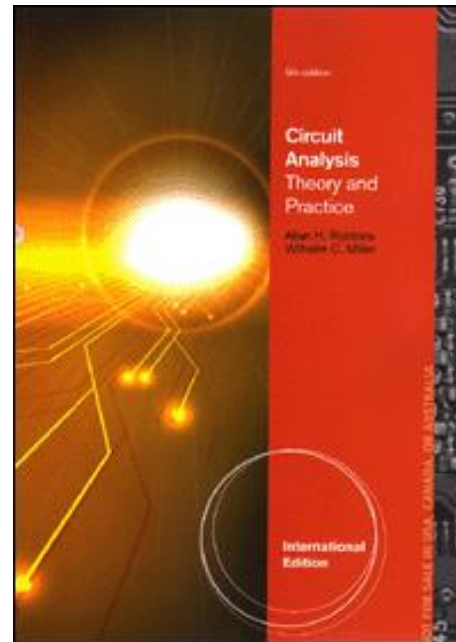
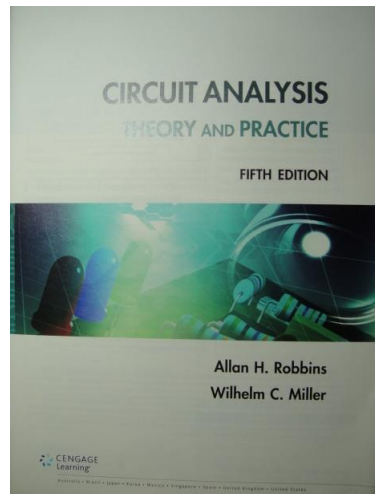

2013

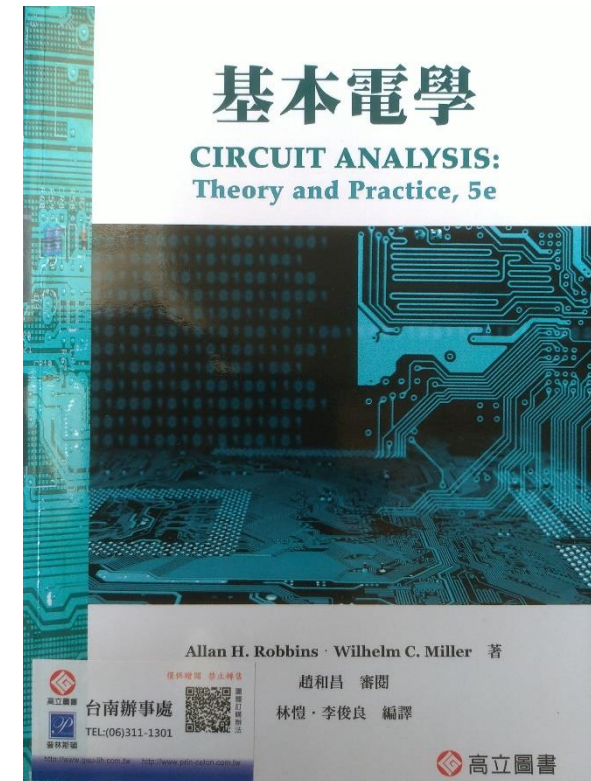

© Delmar Cengage Learning 版權所有，為課本著作之延伸教材，亦受著作權法之規範保護，僅作為授課教學使用，禁止列印、影印、未經授權重製和公開散佈

Course Time and Office Hours

課程時間與辦公室時間

- **Course Time & Place:**
 - **1A: 09:10 ~ 12:00, Tuesday, C219**
 - **1B: 13:10 ~ 16:00, Tuesday, C219**
- **Office Hours & Place:**
 - 善用課間時間諮詢, **Tuesday, C219**



Grading 評量

- **Attendance 出席:** **-3% ~ 5%**
- **Assignments 平時指定:** **35%**
Practice, Quiz, and Homework
實作、小考與作業
- **Midterm Test 期中考:** **30%**
- **Final Test 期末考:** **35%**

Attendance 出席 -3%~5%

- Roll-call 點名 each class
-0.5 each arrival late 每次遲到扣0.5分
- Signature 簽名或點名 each class
-1 for 1st absence 第1次缺席扣1分
-2 each since 2nd time absence
第2次缺席起每次扣2分

Exception(例外): 缺席6次(含)以上將拒絕期末考

- ◆ Final test will be rejected if the number of absences is up to six because your learning has not been recognized to complete this course. 因學習已不完整

Assignments 35 %

- Practices 實作, Quizzes 小考, and homework 作業:
Grading for sum of righted answers in total problems 統計答對的題數或點數
- Deliver your paper/assignments on time:
準時繳交實作、小考及作業
- Don't cheat 不欺騙 for your any assignments

The score would be **zero** once one is verified 確認抄襲或作弊，該項0分

Mid-term Test 30 %

Final Test 35 %

- **3~4-page Problems in English/Chinese 3~4頁**
中英文試題: Closed book and 100 points are maximally graded from 110~125-point problems
- **Don't cheat in any tests 絕不允許作弊對任何考試**
The score would be zero once one is verified.
確認抄襲或作弊，該項0分
- **Open for all the gradings 評量公開、公平**
You can check your grading anytime
- **No 58~59.9 points in term score 學期成績排除**
58~59.9分

Prepare your materials

準備素材

- **Textbook in Chinese or English**
一本教科書 中文或英文
- **Concentration and Passion** 專心與熱衷
- **Make classnotes by yourself**
自行作筆記 或 記錄在教科書上
- **Install Multisim into your PC**
安裝電路分析專業軟體 MSIM 在你的電腦
- **Circuit Drawing/Analysis** 電路繪製/分析
and quiz 小考 (自備白紙或筆記本)
- **Propose your questions anytime** 隨時提問

Teaching Web 教學網頁

<http://www.nhu.edu.tw/~chun>

- [English-Version](#) ● [首頁\(CC Tsai\)](#) ● [簡介\(Biography\)](#) ● [教學課程\(Teaching Courses\)](#) ● [教學績效\(Teaching Awards\)](#) ● [輔導績效\(Counseling Awards\)](#) ● [成績公佈\(Grade Report\)](#)
- [研究\(Research\)](#) ● [著作\(Publication\)](#) ● [學術服務\(Academic Service\)](#) ● [行政服務\(Admin. Service\)](#) ● [社會服務\(Social Service\)](#) ● [校務諮詢委員建言\(Advisory Service\)](#)
- [傑出經驗分享\(Distinguished Sharing\)](#) ● [感言\(Impression\)](#) ● [領悟人生\(Life Review\)](#) ● [永懷國小恩師趙錦堂/僑平國小56級六丙同學會](#) ● [HotLinks](#)



蘭潭, Chiayi



Puerto Vallarta, Mexico, Feb 2018

Video-based Web: 歷年影片參閱

<http://qnew.nhu.edu.tw>



首頁 | QR-code 使用簡介 | 課程影音上傳 | 會員註冊 | 常見問答集 | 系統專區

查詢: 頻道

頻道 節目

最新節目列表 | **預覽次數節目列表**

上一頁 1 2 3 4 5 6 7 下一頁

Podcast 分類:

- 頻道總覽
- 數學類
- 資訊科技類
- 生物科學類
- 管理類
- 經濟類
- 會計類
- 藝術類
- 程式設計類
- 綜合類
- 社科類
- 人文類
- 通識類
- 教育類
- 語文類
- 傳播類
- 宗教類
- 旅遊類
- 財經類
- 音樂類

QR Code:



 <p>MATLAB-三維網格圖、三維曲面圖 預覽次數: 3,827</p>	 <p>程式類-MATLAB-直方圖 預覽次數: 1,560</p>	 <p>MATLAB-底稿練習 預覽次數: 754</p>	 <p>CD光碟重灌電腦步驟簡報檔 預覽次數: 608</p>
 <p>微積分-由微分得到的不定積分公式(三角函數) 預覽次數: 540</p>	 <p>GHOST重灌步驟 預覽次數: 533</p>	 <p>數學類-微積分-高斯函數 預覽次數: 528</p>	 <p>資料結構-Binary Search 預覽次數: 497</p>
 <p>$\lim_{x \rightarrow c} f(x) = L$</p>	 <p>$\lim_{x \rightarrow c} \frac{1}{x}$</p>	 <p>$\lim_{x \rightarrow c} f(x)$</p>	 <p>$f(x) = L$</p>

C-C Tsai



C-C Tsai

Contents 目錄 / 課程內容 for Circuit Analysis: Theory and Practice

Part I Foundation DC Concepts 基礎直流觀念

Ch01. Introduction 簡介

Ch02. Voltage and Current 電壓與電流

Ch03. Resistance 電阻

Ch04. Ohm's Law, Power, and Energy
歐姆定律, 功率 及 能量

Part II Basic DC Analysis 基本的直流分析

Ch05. Series Circuits 串聯電路

Ch06. Parallel Circuits 並聯電路

Ch07. Series-Parallel Circuits 串並聯電路

Contents 目錄 / 課程內容 (續) for Circuit Analysis: Theory and Practice

Midterm Test 期中考

Ch08. Methods of Analysis 分析方法

Ch09. Network Theorems 電路網路定理

Part III Capacitance and Inductance 電容與電感

**Ch10. Capacitors and Capacitance
電容器與電容**

**Ch11. Capacitor Charging, Discharging, and
Simple Waveshaping Circuits
電容器充電, 放電與簡易波形整形電路**



Contents 目錄 / 課程內容 (續) for Circuit Analysis: Theory and Practice

Ch12. Magnetism and Magnetic Circuits

磁原理與磁電路

Ch13. Inductance and Inductors

電感與電感器

Ch14. Inductive Transients * 電感的暫態

Final Test 期末考

Scheduling for CSIE-1A&1B

上課時程

2/22 (Tue), 3/1, 3/8, 3/15, 3/22,
3/29, 4/5(清明節), 4/12,
4/19 (Midterm Test)

4/26 (Tue), 5/3, 5/10, 5/17, 5/24,
5/31, 6/7, 6/14,
6/21 (Final Test)

Remind for Answering to Any Tests

提醒：作答簡潔明確，答案與計算勿混淆

12. Given the internal resistance of a voltage meter, $R_m = 1M\Omega$, please show their reading value and loading effect of circuits (a) and (b).

Handwritten Calculations:

For (a):
 $18 \times \frac{2}{3} = 12$
 $18 \times \frac{10}{12+10} = 8$
 $\frac{12-8}{12} = 0.33 = 33\%$

For (b):
 $18 + \frac{2}{3} = 12$
 $18 \times \frac{0.5}{12+0.5} = 0.72$
 $\frac{12-0.72}{12} = 0.94 = 94\%$

Other Calculations:
 $\frac{1}{2} = 0.5$
 $\frac{0.5}{12.5} = 0.04$
 $\frac{0.04}{18} = 0.0022$
 $\frac{0.0022}{0.004} = 0.55$

Red Text:
 這是做答
 還是計算草稿?

Remind for Answering to Any Tests

提醒：作答簡潔明確，答案與計算勿混淆

1. Given $R_S = 1.5k\Omega$, $R_1 = \text{brown-black-orange-gold}$, $R_2 = 10k\Omega$, and $R_3 = \text{green-black-red-gold}$, determine the voltage drop V_{R_2} and the current I_{R_2} .

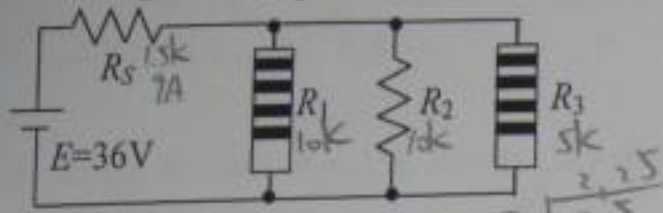

Handwritten calculations for problem 1:
 $10 \times 10^3 = 10k$
 $50 \times 10^2 = 5000$
 $\frac{10 \times 5}{10 + 5} = \frac{50}{15} = \frac{10}{3}$
 $\frac{10}{3} \times 10 = \frac{100}{3}$
 $\frac{100}{3} \times \frac{3}{40} = \frac{100}{40} = 2.5$
 $10 \times 10^3 = 10k$
 $50 \times 10^2 = 5000$
 $\frac{10 \times 5}{10 + 5} = \frac{50}{15} = \frac{10}{3}$
 $\frac{10}{3} \times 10 = \frac{100}{3}$
 $\frac{100}{3} \times \frac{3}{40} = \frac{100}{40} = 2.5$

$V_{R_2} = 27.5V$, $I_{R_2} = 2.25mA$

2. Given a normal-ON LED that has the forward voltage 2.8V and forward current 10mA, find the proper limited resistance R_S such that the circuit can drive 21 LEDs.

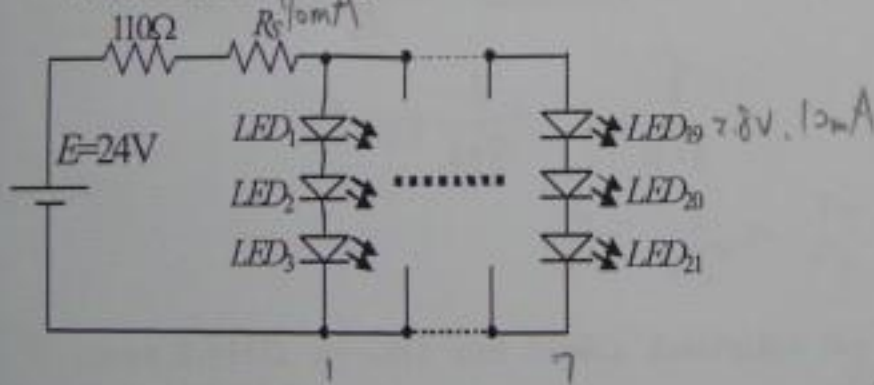

Handwritten calculations for problem 2:
 $(120 + 110 + X) \times 0.01 = 24 - 0.4$
 $2.8 \times 3 = 8.4V$
 $230 + X = \frac{2400}{7}$
 $1610 + 7X = 2400$
 $7X = 790$
 $R_S = \frac{790}{7} \Omega$
 120Ω
 170Ω

Hints for Making Your Classnotes

提示：如自行作筆記 宜條列分明

